

BERETTA

9_{m/m} mod. 951

A product of

THE FIRST ITALIAN
ARMS MANUFACTURER

P. BERETTA S.p.A.

Established in 1680

GARDONE V. T.
BRESCA - ITALY

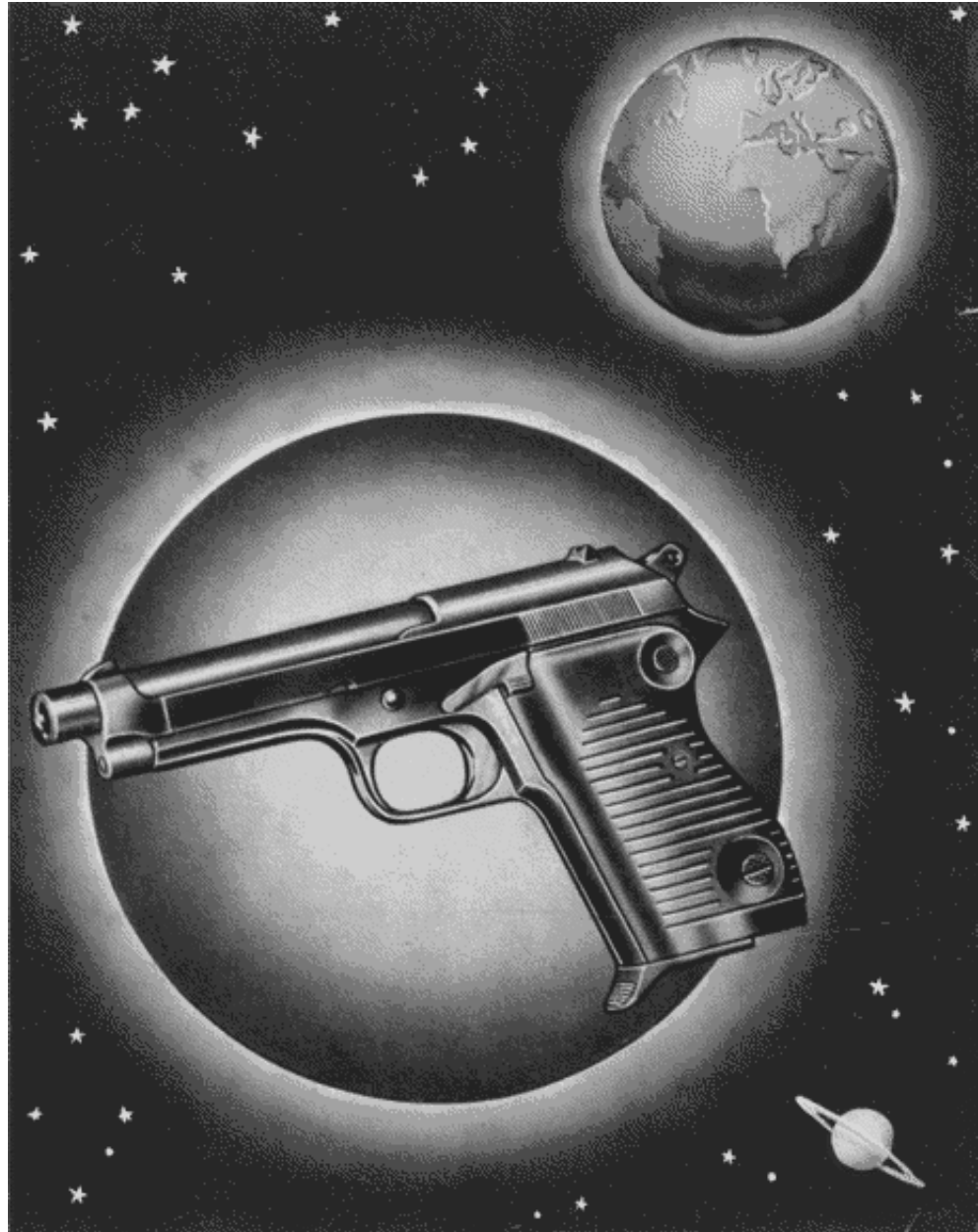

Beretta Model 951



automatic pistol Beretta model 951



Preface

The definite adoption of the 9 mm calibre "parabellum" for the automatic pistols issued to the Armed Forces and Police detachments during the last war, was not only caused by the necessity to unify the calibres of pistols and light machine guns (especially Sten gun type), of ever increasing diffusion with the Armed Forces of the various countries, but also by the excellent ballistic characteristics of this calibre. The difficulties in supply and adequate training as well as the serious inconveniences produced in the logistical sector of operating units, and caused by the existing differences in calibre of the small arms, are well known.

This need for the unification of the small arms calibres was felt most strongly by the Navy and Air-Craft Forces in their special detachments often engaged in isolated raids, landing operations, command actions, police service, etc. And the considerable supply difficulties aggravated by the special displacements of these units (such as bridgeheads, ports, observation points, airports, etc.) made it necessary to reduce the types of ammunition to be issued to each group to the absolute minimum.

To satisfy above-mentioned requirements the "Pietro Beretta" Weapon Factory decided to study and to realize a "9 mm. long" calibre automatic pistol, answering to the above characteristics, and which does represent not only the experiences gained by its staff in the manufacture of over 2 million pistols, but also the results of the studies and experiences of the best foreign industries.

This pistol uses as locking device a vertically sliding, catch, the recharging system is based upon the recoil of the barrel; both operations have already been proved with excellent results by the construction technique here and in the best foreign industries. The system presents, in addition, and compared with that based upon fixed barrel and single gas utilization, with equal cartridge and weight, the considerable advantage of a sensible reduction of the recoil speed with the consequent reduction in the jumping of the weapon during the firing. Outstanding are the excellent results obtained through the use of the light alloy "Ergal" in the manufacture of the body, which made possible the reduction of the weight of the 9 mm long to an only 0,720 kg. (25.4 ozs), using at the same time the ammunition of the light machine gun which is considerable more powerful than the normal 9 mm. long ammunition as used before the war. The weapon, despite its reduced weight, has been especially studied for this ammunition which develops a maximum pressure of 2100 kg/cm² (29,862 lbs/sq.in.).

The cartridge, weighing 7,45 g. (0.25 ozs), possesses an initial speed of 340 m/sec (1164 ft/sec) with a considerable stopping power up to 150-200 m. (500-650 ft).

The 9 mm. short pistol, which forms part of standard equipment of the Italian Army, weighs 0,710 kg. (25.1 ozs), its cartridge, of 6 g. weight (0.21 ozs), develops a pressure of 1200 kg/CM² (17,064 lbs/sq. in.) with an initial speed of 280 m/sec (920 ft/sec). Thus the 9 mm. long, though only very slightly heavier, possesses by far superior ballistic characteristics.

The experiences of the recent Korean war proved that an individual defense weapon of high ballistic qualities is still required, the more so against the dangers of enemy raids and partisan warfare met with during the supply and contact service, and which demands a ready reaction based upon efficient weapons of outstanding offensive power.

Modern warfare, in fact, created the phenomena of guerrilla warfare which takes place at the flanks, of the operational army units, and the use of pistols and light machine guns, despite the development of new weapons possessing a very high destructive power, cannot yet be considered as obsolete even in modern theatres of war.

Main Characteristics

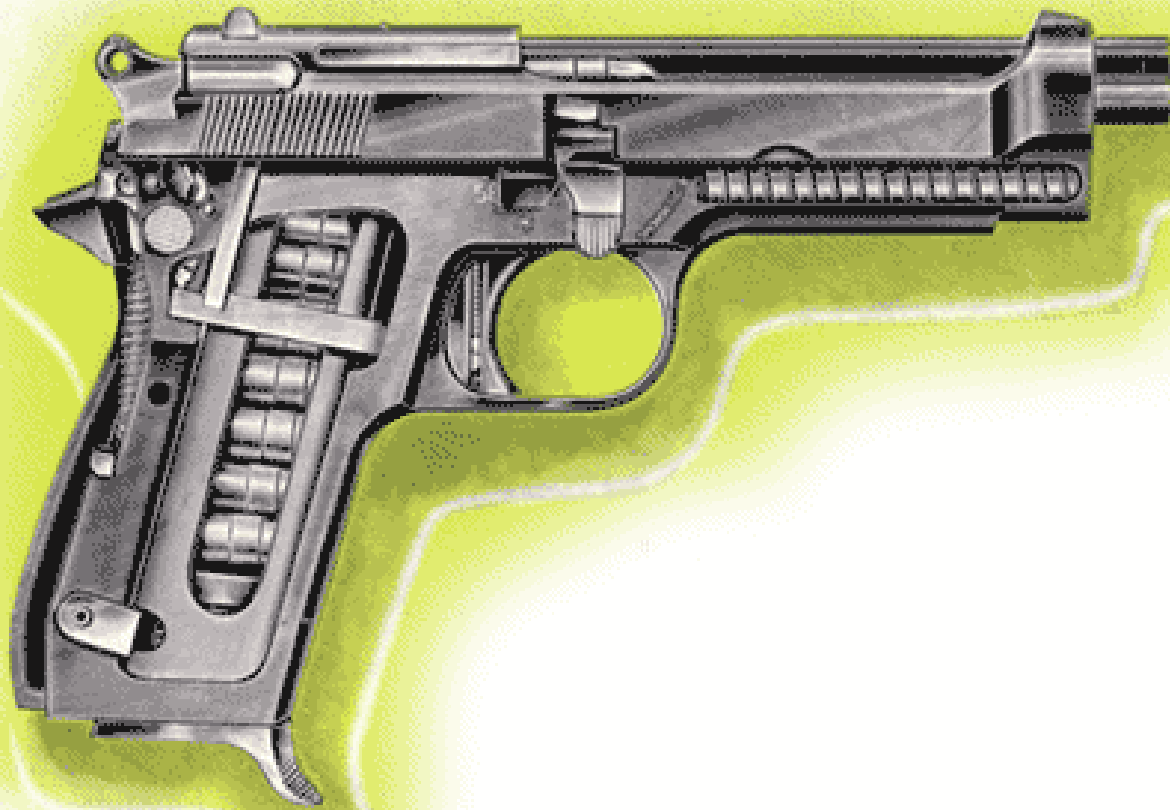

| | |
|-------------------------|---|
| System Operation | Recoil barrel locked by a vertically sliding catch |
| Magazines | Standard magazine charge: 8 rounds Special magazine charge: 10 rounds (a further round may be placed into the chamber) |
| Weight | Weight of the weapon with magazine (but without holster): |
| | Steel (frame) body: 890 g. (31.4 ozs) |
| | Ergal (frame) body: 720 g. (25.4 ozs) |
| Caliber | Calibre: 9 mm. |
| | Cartridge: 9 long standard for pistols and machine pistols «(parabellum ») or sub-machine guns |
| | Maximum recoil speed of bolt approx. 7,5 m/sec (24.6 ft/sec) |
| | Weight of cartridge: 7,45 g. (0.25 ozs) |
| | Weight of charge: 0,39 g. (6 grains) |
| | Initial speed V 10: approx. 340 m/sec (1164 ft/sec) |
| | Maximum gas pressure: 2100 kg/CM2 (29,862 lbs/ sq. in.) |

Nomenclature



Bolt Assembly
Bolt, Barrel, Locking Block, Recoil
spring, Recoil spring guide

Barrel Assembly
Barrel Locking Block

Recoil spring Recoil spring guide

Body (Frame) Assembly

Magazine Assembly

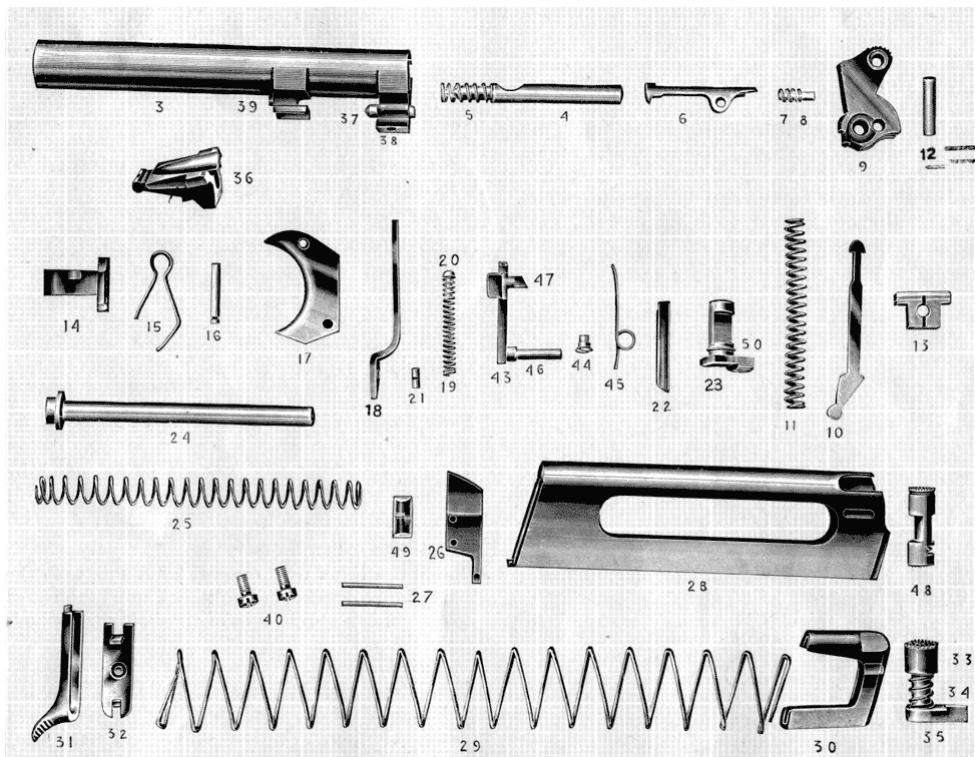

Main Parts

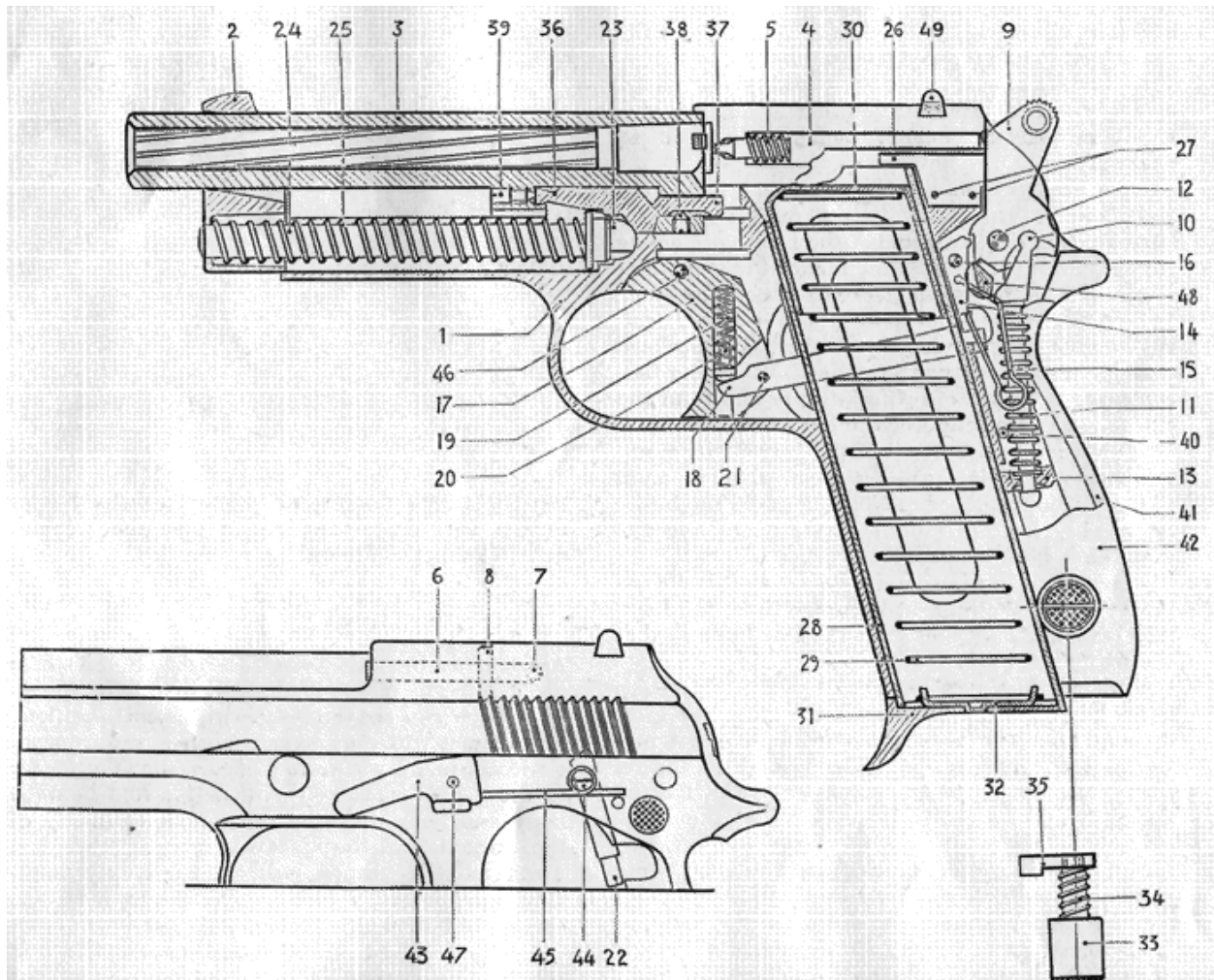

| | | | |
|------------------------------|---------------------------------------|------------------------------------|----------------------------------|
| 1 Body | 14 Sear lever | 27 Ejector pin | 40 Check Screws |
| 2 Bolt | 15 Sear Lever and Safety Catch Spring | 28 Magazine Chamber | 41 Right Check |
| 3 Barrel | 16 Sear Lever Pivot | 29 Magazine Spring (Feeder Spring) | 42 Left Check |
| 4 Percussion Pin | 17 Trigger | 30 Magazine Feeder | 43 Bolt Catch Lever |
| 5 Percussion Pin Spring | 18 Trigger Lever | 31 Magazine Base | 44 Bolt Catch Lever Spring Screw |
| 6 Extractor | 19 Trigger Lever Spring | 32 Base Plate | 45 Bolt Catch Lever Spring |
| 7 Extractor Spring | 20 Trigger Lever Spring Rod | 33 Magazine Catch Button | 46 Trigger Pivot |
| 8 Extractor Pin | 21 Trigger Lever Pivot | 34 Magazine Catch Spring | 47 Bolt Catch Lever Pin |
| 9 Hammer | 22 Trigger Lever Disengaging Rod | 35 Magazine Catch | 48 Safety Catch |
| 10 Hammer Spring Rod | 23 Disassembling Catch | 36 Locking Catch | 49 Rear Sight |
| 11 Hammer Spring | 24 Recoil Spring Rod | 37 Locking Catch Control Pin | 50 Locking Catch Spring |
| 12 Hammer Pivot | 25 Recoil Spring | 38 Control Pin Screw | 39 Catch Screw |
| 13 Hammer Spring Rod Support | 26 Ejector | | |

Instructions

Grip the pistol with the right hand and with the left introduce the magazine pushing it well into the chamber until it is locked by the catch. Grip the bolt by the checkered part pulling it back with a quick move, then let it snap forward (this operation will be accelerated by previously lowering the hammer). The weapon is now loaded and ready to be fired.

Pulling now the trigger the trigger lever is pushed back against the hammer catch and throws it over, liberating thus the hammer which, in turn, is pushed forward by its compressed spring hitting the percussion pin and firing the weapon.

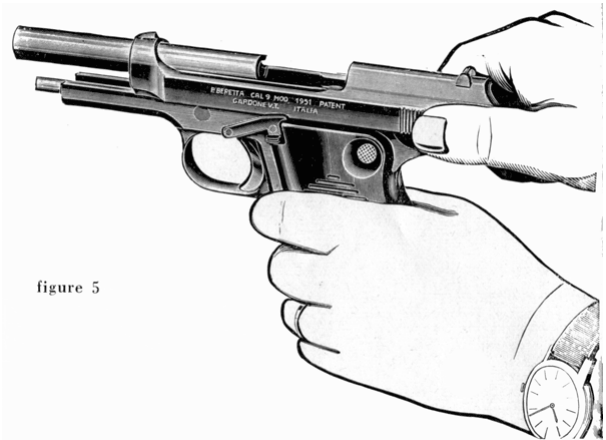

figure 5

The firing mechanism of this weapon differs from previous Beretta models in that it presents a very high sensibility without, however, the danger of any untimely firing. This model, like the other models, possesses a hammer controlled by two catches, of which the first one, the safety catch, stops the hammer in case of insufficient lifting; preventing thus that it hits the percussion pin.

After the firing of a round the expanding gases act against the cartridge case pushing it and the bolt together with the barrel, tightly locked to it, backwards.

After a backward movement of about 7 mm. (1/4 inch) pin (37) provided in the rear end of the barrel hits against an angle of the body and, acting with its front end against the inclined recess at the lower part of the locking catch, forces the latter to turn downwards, and to introduce its lateral guides into the slots provided on the bolt. The backward movement of the barrel is stopped, while the bolt continues its recoil effecting at the same time the extraction and ejection of the empty case.

The duration of the recoil of the barrel-bolt group has been studied in such a way that, at the moment of the disconnection of the locking catch the bullet has already left the mouth of the pistol and the gases have been completely dispersed.

The recoil spring is compressed by the backward movement of the bolt, at the same time, the hammer is turned back and grips the sear lever so that the weapon is again ready.

Completed the recoil, the recoil spring carries the bolt again forwards. During this move the bolt grips a round from the magazine and introduces it into the chamber, carrying at the same time the barrel forward to its original position while the locking catch, forced by the inclined recess at the lower side, which slides on a corresponding inclined surface, is turned upwards introducing its guides into the respective slots provided on the bolt.

The trigger lever, during the recoil of the bolt, has been forced down by the disconnecting lever (22) (controlled by the ribs of the bolt), and is thus disengaged from the sear lever which returns into its original position. Thus a continuous uncontrolled firing of the weapon is made impossible even if the pressure is kept by mistake upon the trigger. Leaving the trigger free, its lever is lifted and reengages the sear lever pivot; the weapon is again ready to be fired. Renewing successively the pressure upon the trigger, the above described operations will repeat themselves and the weapon will fire until the magazine is emptied.

Empty magazine:

As soon as the last round is fired and its case ejected, the magazine feeder will lift the bolt stopping catch and fix the bolt in the recoil position; the weapon will thus remain open and the inconvenience, found with other pistols, that the feeder of the empty magazine becomes blocked between body and bolt, with the

subsequent difficulty of the extraction of the magazine case, is prevented. To reload the weapon pull out the empty magazine case, insert a full magazine and push the checkered button of bolt stopping lever downwards; the latter, sliding down, will disengage the bolt which slides again forwards, introducing at the same time a new round from the magazine into the chamber of the barrel. The weapon is ready to be fired. This return of the bolt into forward position could also be affected by "ripping the checkered part of the bolt and drawing it back. The lever, pushed by its spring, will slide down and disengage the bolt. (see figure 5).

Round in barrel:

With a round in the barrel the end of the extractor remains slightly lifted and covers a red-marked sign; the position can also be felt by touch only.

Safety catch:

The safety catch has been designed to function only with loaded hammer, it blocks at the same time the hammer and the sear lever. Pushing the button of the catch from right to left the catch will engage the two devices, pushing from the left to the right; they will be disengaged at the same moment.

This device has been studied to allow maximum speed to obtain the firing position, i. e., by simply pushing the button with the thumb of the hand holding the weapon. The location of the button is such that, an involuntary passage from the safe to the firing position is practically impossible.

With the weapon not in ready position the safety catch need not be engaged as the percussion pin is completely blocked and kept in this position by its spring without extruding into -the breech: with a round in the barrel the weapon could not fire even if the hammer should be pulled by accident.

Disassembling

Disassembling of the weapon is carried out as follows:

- 1) make sure that the weapon is unloaded by observing the position of the extractor end;
- 2) pull the hammer
- 3) pull the magazine out
- 4) grip the pistol with the left hand and, with the left hand, push the bolt back until the recess cut into the right side of the bolt corresponds to the position of the disassembling catch (figure 6);
- 5) stop the bolt with the fore-finger of the left hand in this position to allow the turning of the checkered button of the disassembling catch;
- 6) turn the button by a quarter turn in direction of the arrow etched into the body (see figure 7).



Barrel and bolt are now disengaged and can be easily slid off the body. To disengage the bolt from the barrel, take out the recoil spring and press the button which operates the locking catch. The barrel will then easily slide off the guides. For reassembly repeat the same operations starting with the last; rotating first the checkered assembling catch button into the position shown on figure 7.



Cleaning

The weapon, when not too dirty, can be cleaned easily, and it is quite sufficient to disassemble the barrel, the locking catch, bolt, the recoil spring, and recoil spring guide.

It is, however, necessary to clean the barrel after the use of the pistol, if possible, by washing it with petrol or kerosene, drying well and carefully, and oiling slightly with non-acid oil (Vaseline, neutral oil, etc.).

Should the weapon, however, be very dirty, covered with dust, dirt, or show traces of rust, it will have to be completely disassembled; then all parts have to be thoroughly washed as before and dried with soft rags. After completely cleaning, oil slightly with Vaseline or neutral oil.



Maintenance

The main rules to keep the weapon in good firing order are:

1. check the barrel before firing and control the functioning of the various parts;
2. control the magazine for possible deformations, especially along the lips, and check the regular functioning of the feeder spring;
3. should a stoppage occur, stop firing and act as instructed below;
4. inspect the weapon after firing, clean and oil.

Stoppages

The most important stoppages which may occur are: misfire - incomplete locking - missed feeding - blocked cartridge case - blocked round.

Misfire

This trouble can be caused by deformation or rupture of the percussion pin, by a weak hammer spring, defects of the round, by dried oil, dirt, or other material blocking the free sliding of the percussion pin, by incomplete locking caused by a weak recoil spring or dried oil and dirt in the grooves of the bolt. Recharge hammer and repeat the firing. Should the stoppage re-occur, eject cartridge from the barrel by pulling the bolt back. If the stoppage continues, control the parts indicated above and substitute those which are damaged, used, or broken.

Incomplete locking

Incomplete locking can be caused by weakness or rupture of the recoil spring, or by dried oil and dirt in the grooves of the bolt guides, on the surfaces of the locking catch slide planes, or in other devices controlling the functioning of the various parts.

Unload weapon, check spring and change if required: if necessary, clean the weapon with special attention to the grooves and planes.

Missed feeding

Missed feeding is caused by a weak feeder spring, damaged magazine case, or faulty functioning of the magazine locking catch. - check and replace as required the faulty parts.

Blocked - cartridge case

The cartridge case can be blocked by faulty functioning of the ejector or extractor or the respective spring; by incomplete recoil of the bolt due to foreign matter in the sliding grooves: take out the magazine, pull the bolt back and shake the case out, check ejector and spring and change if faulty; at the same time clean the grooves.

Blocked round

Take out the blocked round; if the stoppage repeats check the functioning of the feeder spring, the lips of the magazine for possible damage; change whatever parts may be damaged. Control also the magazine locking each.